

Can the Building Permit Process ever get better? The answer is yes.

Starting late last year AIA | DC ran a survey on permitting issues to which many of you responded. Don't take our recent silence on the matter to mean we have forgotten all about it – far from it! Many people are hard at work trying to figure out a lot of really knotty problems that make our process so complex.

Our friends at DCBIA have called this situation “the perfect storm” because all the parts of ProjectDox have been phased in, plus there are additional requirements from DDOT, DOEE, DC Water, among others. It certainly can't get much worse than it is right now. But as frustrating as it is there is a lot of opportunity for change. A group of us have been meeting with people from DOEE staff to try and make a few processes simpler. We will keep you updated on our progress.

One of our questions to you in the survey was “What do you think AIA | DC should do to help?” A few of you came back with something close to “Why do you think they'd care what the Chapter thinks?” Thankfully, our recent efforts have shown that

they really do care what we think because we represent more than 2200 people doing business in DC. We can make a difference, one step at a time.

In case you were curious about the results of the survey here they are:

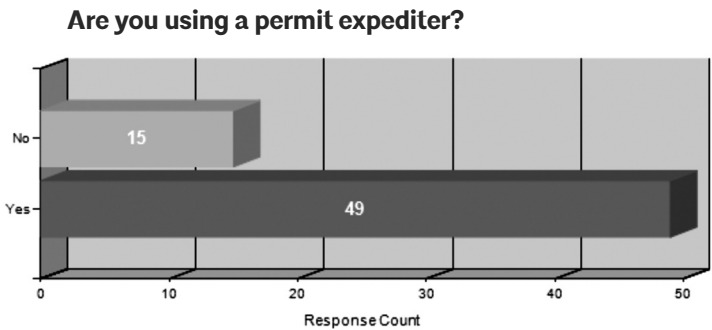

(continued on page 3)





Happy Fifth Birthday, District Architecture Center!

Join us on May 12 to celebrate the 5th anniversary of the District Architecture Center at the Thing in the Spring! This event will not only be a fantastic networking opportunity for people in the real estate, design, development, and architecture industries, but also celebrate the arrival of the beehive on our roof. Mix and mingle as you view a video stream of the bees!

Enjoy the full open bar and toast to a great cause as we give out this year's Barbara G. Laurie Scholarship and support the wonderful work of the Washington Architectural Foundation.

View aiadc.com/calendar to register.

Benefactor

- Syska Hennessy Group

Sponsors

- Interface Engineering
- U Street Parking

Supporters

- Ames + Gough Insurance / Risk Management Inc.
- Bialek + DIRT
- Critical Systems, LLC
- DES-DC, Inc
- Metrix Construction
- Think Make Build
- Casaplex + Crestron

Contributor

- Potomac Energy Group

AIA|DC'S Newest Members

Please welcome our new and returning members!

- Tanya Ally, AIA
- Erica Aronson, Assoc. AIA
- Marisa Aschettino, Assoc. AIA
- Marielle Asenjo, Assoc. AIA
- Alexander Ayala, Assoc. AIA
- Marco Barboza, Assoc. AIA
- Vernadette Beal, Assoc. AIA
- Kris Benson, AIA
- Sarah Buffaloe, Assoc. AIA
- Erin Carlisle, AIA
- Mercedes Chaparro, Assoc. AIA
- Marvin Chavez, Assoc. AIA
- Tiara Cypress, Assoc. AIA
- Nicole Dallaire, Assoc. AIA
- Amir Ali Ebadi, Assoc. AIA
- Luis Estrada-Cepero, Assoc. AIA
- LaNilta Farrior-Taylor, Assoc. AIA
- Christina Fazio, AIA
- Patricia Ferrari, AIA
- Katherine Floersheimer, Assoc. AIA
- Eduardo Frontera, Assoc. AIA
- Susan Garcia, Intl. Assoc. AIA
- James Gloeckner, AIA
- Brandon Graham, Assoc. AIA
- David Hathcock, Assoc. AIA
- William Herrick, Assoc. AIA
- Vanessa Hostick, Assoc. AIA
- Charishma Hunjan, Assoc. AIA
- Christine Kandigian, AIA
- Brynn Kurtzman, Assoc. AIA
- Yoonho Lee, Assoc. AIA
- Johanna Lofstrom, AIA
- Nathan Logston, AIA
- Javier Jose Maymi, AIA
- Samuel McGuire IV, AIA
- Samantha Melcher, Assoc. AIA
- Juan Ramon Morales, Assoc. AIA
- Lauren Nelson, Assoc. AIA
- Dean Reineking, Assoc. AIA
- Alexandra Rio, AIA
- Erica Rokenbrod, Assoc. AIA
- Katherine Russett, Assoc. AIA
- Brian Szymanski, AIA
- Andrea Wilbourn, Intl. Assoc. AIA
- Devin Wilkins, AIA

AIA|DC 2016 Board of Directors

| | | | | | |
|-----------------------|--------------------------------|------------------------|-------------------|----------------------------|--------------------|
| Sean Stadler, AIA | President | Marcy Giannunzio, AIA | Director at Large | Yiselle Santos, Assoc. AIA | Director at Large |
| Carolyn Sponza, AIA | Vice President/President Elect | Rob Holzbach, AIA | Director at Large | Bill Spack, AIA | Director at Large |
| Joe Sacco, AIA | Treasurer | Diana Horvat, AIA | Director at Large | Todd Steighner, AIA | Director at Large |
| Marc Fairbrother, AIA | Secretary | Franklin Kaye, AIA | Director at Large | Luis Velez-Alvarez, AIA | Director at Large |
| Steve White, AIA | Immediate Past President | Douglas Palladino, AIA | Director at Large | Mary Fitch, AICP, Hon. AIA | Executive Director |
| Jason Arnold, AIA | Director of Public Architects | | | | |

AIA|DC News is published monthly on the by the Washington Chapter of the American Institute of Architects and is distributed to over 2,200 AIA|DC members and corporate and professional affiliates in the Washington, DC metropolitan area. The News is printed on Rolland Enviro 100, a 100% post-consumer waste paper.

The editorial deadline for each issue is the first day of the preceding month. Submissions received after this date may be held for publishing due to spatial

limitations. Editorial contributions and letters are welcome. We reserve the right to edit submissions. Opinions expressed by contributing authors do not necessarily reflect the policies or views of the Washington Chapter/AIA, or its officers, directors, or employees.

EDITOR

Asya Snejnevski

MEMBER NEWS ITEMS

newsletter@aiadc.com

AIA|DC STAFF

Mary Fitch, AICP, Hon. AIA
Executive Director
 Katherine Adams
Development Director
 Scott Clowney
Exhibitions Manager
 Will Dawson
Gallery Assistant
 Melody Harrison
Member Service and Committee Liaison Director
 Laura Headrick
Events Manager

Sinlaire Erdwien
Education and Committees Coordinator
 Heritage Honey
Beekeeper
 Beth Judy
Foundation Programs Manager
 Asya Snejnevski
Communications Coordinator
 Katie Spencer
Programs Director

ADVERTISING SALES MANAGER

Jody Cranford 800-818-0289
jcranford@aiadc.com

Can the Building Permit Process ever get better?

The answer is yes. *(continued from cover)*

Do you think it's helped to speed the process?

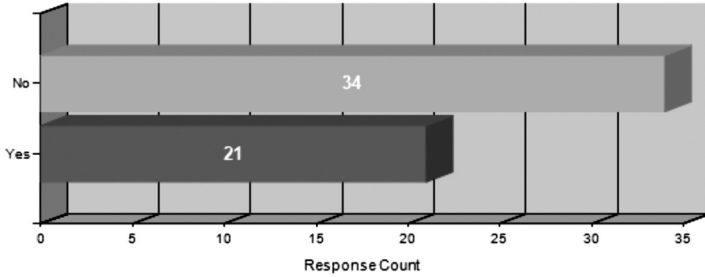

Are you using third party review?

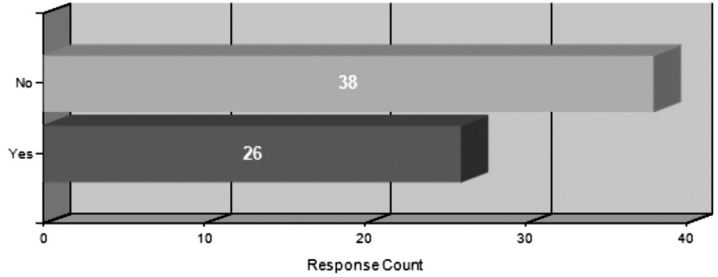

If you are using third party review, do you think it has helped improve the speed of receiving your permit?

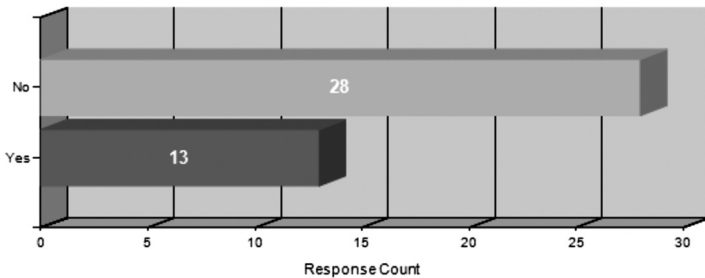

Have you found that pursuing LEED certification has reduced the review and approval time for the Green Building Act?

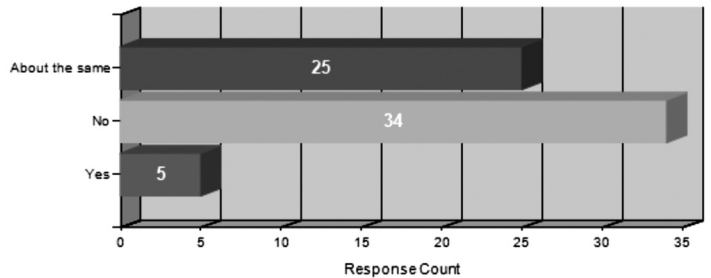

Do you find reviews by DOEE extend the process or are about right?

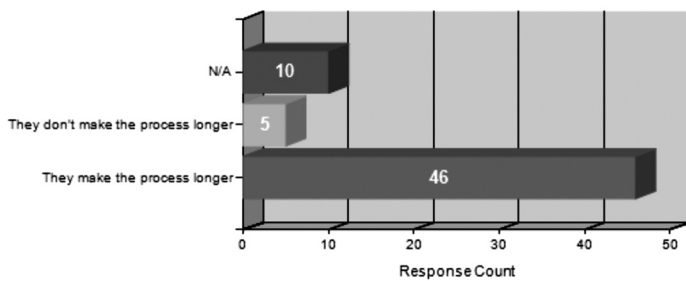

Do you think DDOT review makes the process longer?

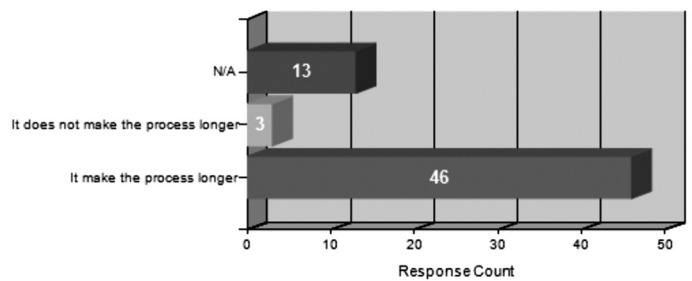

We got a lot of good ideas and comments from many of you. Many of you are quite, well, passionate on this subject so we aren't going to print your answers here but please know that we

are hard at work trying to turn things around. All of this is going to take an enormous amount of patience but we are already starting to see small glimmers of improvement.

*By Mary Fitch, AICP, Hon. AIA,
Executive Director*

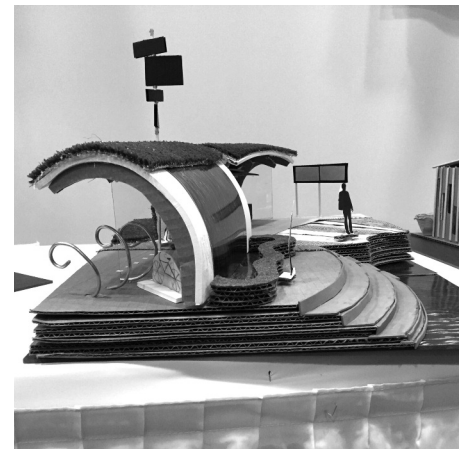

Archi-Builders Put on a Show at the USA Science and Engineering Festival

Volunteers and staff from the Washington Architectural Foundation joined the Girl Scouts Nation’s Capital participants from our Archi-Builder program at the Washington Convention Center for the amazing USA Science and Engineering Festival at the end of April. The Archi-Builders showed off the models they constructed of a creative and sustainable development to the more than 365,000 visitors who came to the Festival.

The WAF booth was in the thick of things with neighbors from NASA, Lockheed Martin, and the Carnegie Institution for Science, to the Federation of Galaxy Explorers and the Joint Quantum Institute. Dedicated WAF volunteers, Lam Vuong, Joanna Schmickel, and Gina Volpicelli – working

with a host of others – led the charge for the Archi-Builder workshop series at the District Architecture Center this winter that engaged 32 Girl Scouts over the several months leading up to the Festival.

The science Festival was featured on local TV news throughout the weekend and the WAF booth drew huge crowds with lots of interest in learning more about programs at DAC.

To find out more about DAC programs for kids (and adults), to support DAC programs, and to offer your expertise as a volunteer, check out wafonline.org or get in touch with Asya Snejnevski at asnejnevski@aiaadc.com or 202-347-9403.



Selling Your Design Firm IOI: The Internal Transition

By Matthew J. Gaziano, Esq., Lee & McShane, PC

When a successful architect wants to retire and sell the firm, there are two common concerns related to transition of the firm:

1. Receiving fair financial compensation for the goodwill and other assets of the firm; and
2. Continuing to operate and provide employment for those who have made the firm successful.

In a series of articles, we will review the various options available to effectuate a successful transition of an architecture firm.

This first article reviews one of the most common options for transition of an architecture firm: the internal ownership transition. Architects at all stages of their career should be familiar with the internal transition – those nearer the end of their career need to be planning their transition out of the firm, while those nearer the

start should understand the expectations for acquiring ownership through an internal transition.

Typically, the retiring architect sells his/her ownership stake in the firm to a licensed architect who wants to take over and lead the firm, combining a promotion with a transition to equity ownership for the purchaser. With that ownership comes the right to a percentage of the profits, i.e., the earnings after salaries and bonuses for all employees. The sale can transfer full ownership of the firm, or it may transfer partial ownership. The seller usually provides financing by taking a promissory note and receiving payments over a period of years (which come from the profits that the purchaser receives).

The internal transition often includes employment agreements for the seller. The seller often agrees to continue doing business

development or to assist the purchaser develop management skills. Ideally, the seller should work long enough to ensure the transition succeeds, ensuring that the firm generates enough profits for the buyer to complete the buyout. This employment agreement usually includes a non-compete provision.

Many firms—small and large—have successfully implemented internal transitions across multiple generations. While it requires advanced planning, an internal transition can be a satisfying way for an architect to retire. Using the internal transition model is highly effective and is an option that all architects should consider, particularly when the firm has created a culture of advancement and increased responsibility among its younger architects.

KH KEAST & HOOD

STRUCTURAL ENGINEERS



Harbor of Refuge Lighthouse | Lewes, Delaware

New Construction • Renovation • Addition • Adaptive Reuse
 Historic Preservation • Masonry Stabilization • Structural Intervention

www.keasthood.com

Philadelphia | Washington | Charlottesville



Industry Leaders in Engineering Services

With a talented and dedicated staff of over 1,100 professionals specializing in mechanical, electrical, plumbing, fire protection, civil, and structural engineering, traffic engineering, survey/mapping, and program management, we can meet and exceed our clients' expectations on any size project.

Learn more at www.gpinet.com



Building Assessments || Construction Documents || Peer Review || Continuing Education
 Sustainable Design || LEED || Green Globes || Energy Modeling || Commissioning
 Locations throughout the US

CADD

CADD MICROSYSTEMS

Realize your full potential with BIM

We can help you get the ROI you want from your design processes and software, like Autodesk Revit, Navisworks and Bluebeam.

We're here to help you:

- ⊕ Make the transition to 3D and BIM, to leverage the benefits of modeling
- ⊕ Maximize the benefits of the technology you've purchased
- ⊕ Evolve workflows and processes to use your model data more efficiently
- ⊕ Streamline workflows and create design standards
- ⊕ Seamlessly update processes and roll out learning paths

Get the unrivaled expertise of CADD Microsystems on your team, and we'll bring with us our decades-long partnerships with industry leaders like Autodesk, Bluebeam and Global eTraining.

CALL: 800.550.CADD | **CLICK:** www.caddmicrosystems.com/tpa



AIA | DC members may submit “Member News” items to newsletter@aiadc.com.

A

Maryjane King, AIA of **Atelier MjK** was recognized by the Sokol Media publication, DC Rising, as one of the Top Women to Watch in Real Estate. King, principal of Atelier MjK, is one of 14 women who was showcased during the event's luncheon on April 12th at the National Press Club.

B



UDC Green Roof

BELL Architects received the 2015 AIA | DC Presidential Citation for Design and Well-Being for their work on the UDC Urban Agriculture Roof. The project included master planning and implementation of green roofs and a rooftop farm on campus buildings as part of a DDOE grant. They were also selected to design the DC DGS Therapeutic Recreation Center, targeting LEED Gold. The program includes a therapy pool, park with ball fields, walking paths and activity centers, emphasizing project goals for energy and water conservation and universal accessibility. BELL Architects also welcomes Ana Paraon, an award-winning designer, and Carol Tudor Beach, marketing coordinator to their team.



Ana Paraon
of Bell Architects



Carol Tudor Beach
of Bell Architects

Bialek welcomes **Andrew West, Assoc. AIA, LEED AP BD+C** as marketing strategist. An integral part of the design, client services and sales teams, Andrew designs and implements outreach and engagement opportunities for a variety of audiences: end users, architecture and design partners, and facilities managers.



Andrew West

E

EYP Architecture & Engineering announced the promotion of **Robert McClure, AIA**, to Lead Designer in the firm's Washington, DC office. McClure's new role includes spearheading company-wide design efforts to ensure the highest levels of design quality, providing mentorship across the firm, and partnering with leadership to promote EYP's brand identity as it continues to expand into new sectors and geographic markets. McClure's portfolio includes over 20 million square feet of significant higher education, government, mixed-use, residential, corporate, and commercial high-rise projects.



Robert McClure, AIA

G



New America Foundation

GPI provided engineering consulting services to design the mechanical, electrical, plumbing, and fire protection systems for the 50,000 square foot New America Foundation offices. The scope of work included the 8th, 9th, 10th, and 11th floors. In addition to typical office space, specialty areas included a Main Events room requiring a dedicated rooftop unit and Recording and Editing Studios and Control Room to dedicated rooftop unit, Recording and Editing Studios, and Control Room for TV production. The project will be pursuing LEED certification.

Real or 3d?

We Help Bring Your Visions to Life!
email: info@3dstormstudio.com



www.3dstormstudio.com

3D Virtual Staging

3D Conceptual Designs

3D Architectural Renderings

3D Walkthrough & Flyby Animations

We Provide High Quality 3d Architectural Rendering & Animation Services in Metro DC

3DSTORMSTUDIO
ARCHITECTURAL RENDERING AND COMPUTER GRAPHICS SERVICES
1050 Connecticut Avenue, NW, 10th Floor, Washington, DC 20036

Call 571.243.0236



TECHNICAL
CAPABILITIES.

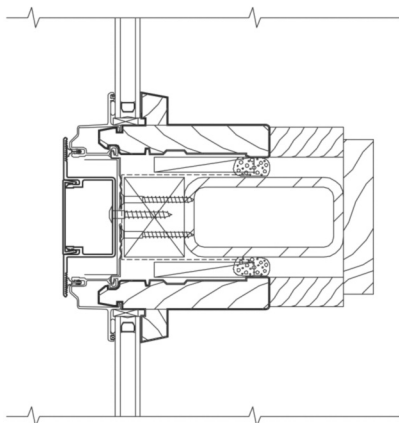

VERTICAL MULLION

ENVIRONMENTAL NATURE CENTER
NEWPORT BEACH, CA
ARCHITECT: LPA, INC.

EDUCATION

CREATIVE
POSSIBILITIES.



Pella Windows & Doors

Timothy R. Allen

12100 Baltimore Avenue, Suite 1

Beltsville, MD 20705

Cell: 301-675-9324

Phone: 301-957-7000

Email: tallen@kc-pella.com

pellacommercial.com

See both sides of this story at pellacommercial.com/enc.



COMMERCIAL
SOLUTIONS

© 2014 Pella Corporation
Photo © Costea Photography, Inc.

H

HENRY ADAMS (MEP Engineers) announce that the scholarship presented in the name of its founder has been awarded to Rachel Kendall. Kendall is an undergraduate mechanical engineering student at the University of Manitoba (Canada). Recipients are chosen based on studies at a 4-year institution, character, accomplishments, and likelihood of success in the HVAC and/or refrigeration industry.

Eric Sternberg has been hired as Senior Electrical Engineer to HENRY ADAMS; Sternberg comes to the firm with eight years of experience on multi-family and healthcare projects.

Adam Palanker spent a day helping at the Maryland School for the Blind as part of the Go Kids Go program, helping build and modify electrical systems to power wheels in order to adapt them for children with special needs.

K

In June 2015, Amtrak hired **KGP Design Studio, Grimshaw Architects, and ARUP** to achieve 100% design and construction phasing for the Union Station Passenger Concourse Modernization Project, which has reached 30% design as of March 2016. Early action construction work will begin in the summer of 2016, including the relocation of key support services now impeding passenger circulation. The entire project is anticipated to be completed in 2019 in advance of the introduction of a new Acela fleet, which is accompanied by more frequent service.

L



Project manager Allen Apple, project designer Armin Bondoc, principal Ethan Landis, lead carpenter Ken Guillet, lead carpenter Carlos Marin, carpenter Steve Bonausti, director of architecture Paul Gaiser.

Landis Architects/Builders recently won three awards from the National Association of the Remodeling Industry's Capitol Contractor of the Year awards. The Grand Award was awarded for a commercial office project in a Capitol Hill row house that included a conference room and apartment/sitting area. Landis received two Merit Awards, one for a historic renovation and addition to a Takoma Park, MD bungalow and the other for an attic master suite in the Crestwood, DC neighborhood. The team received the awards during the NARI gala.



August 24-26

www.aiadesigndc.org

Registration is now open
for **DesignDC 2016!**

AIA|DC members: register before
May 31 to take advantage of
special discounted *Super Saver*
registration fees!

**FROM THE
GROUND**

**Located at the
Walter E. Washington Convention Center,
with tours in DC, MD, and VA**

**Earn AIA, GBCI, AICP, ASLA,
IIDA, LACES, and PDH credit**

Presented by AIA|DC, AIA Potomac Valley, AIA Northern Virginia, the Mid-Atlantic Chapter of the International Interior Design Association (IIDA - MAC), the National Capital Area Chapter of the American Planning Association (APA), and the Potomac Chapter of the American Society of Landscape Architects (ASLA).

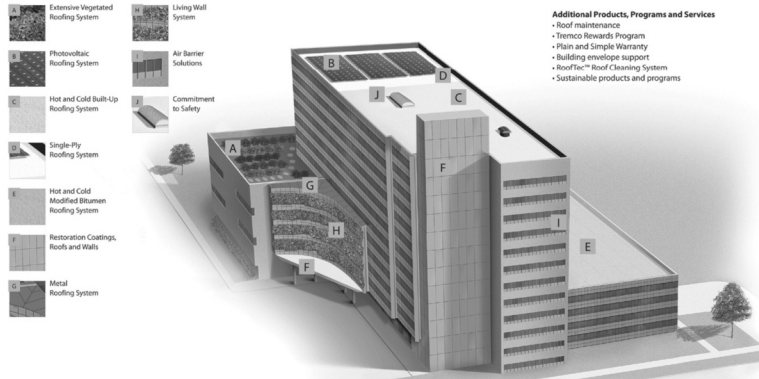
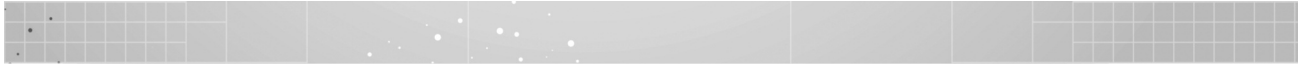

Resilience Starts At The Top. With Tremco, It Doesn't End There.

Our commitment to resilience reflects an 80-plus-year philosophy of extending buildings' lives through restoration and retrofitting.

From the Top: Our vegetated, photovoltaic and white reflective built-up roofs, coatings and single-ply membranes do more than securely weatherproof your facility. They can help facility managers and owners operate more resilient buildings, with improved energy and water management and lower carbon output. Using recycled content and asbestos-free materials in our roofing systems' construction makes them even friendlier to the environment.

And All Around: But that's just the roofs. We have solutions to improve the resilience and longevity of the entire building envelope – walls, foundations, façades, controls and much more – through general contracting, preventive maintenance, sealants and weatherproofing, all of which can help make your buildings less expensive to operate.

For more information, contact: Marty Jakovics, CSI, CDT, Tremco Roofing and Building Maintenance
Cell: 443-928-9173 • Email: mjakovics@tremcoinc.com

TREMCO
ROOFING & BUILDING MAINTENANCE

www.tremcoroofing.com
1.800.562.2728

©2015 Tremco Incorporated.

BEEN HERE FOR 130 YEARS. BE HERE FOR AT LEAST 130 MORE.



PV
BRICK
POTOMAC VALLEY BRICK

www.pvbrick.com
301.309.9600

BUILD WITH BRICK.

M



MTFA Architecture's 2311 Wilson Boulevard

MTFA Architecture's 2311 Wilson Boulevard building has a new tenant: Opower, a global leader in energy saving software for the utility industry. Early in design, MTFA Architecture branded 2311 Wilson Boulevard "The Clean Technology Center." It's a happy coincidence that the pet name for the building attracted an energy-conscious company that in 2010 President Obama called a "model of what we want to be seeing all across the country."

MV+A Architects announces the promotions of Neville Fernandes, AIA, LEED AP; Brian Syzmanski, AIA, AICP, LEED AP; and Russell Zung, AIA, LEED AP to Associate.

Fernandes leads MV+A's design efforts on several urban mixed-use projects, including Half and N Street and 965 Florida Ave. Syzmanski specializes in planning and design of complex mixed-use sites, including the McMillan Sand Filtration redevelopment and new projects in Charlotte and Pittsburgh. Zung builds client relationships and provides comprehensive design documents on projects such as Riverdale Park and 4735 Bethesda Avenue. As Associates, they will continue to develop their roles in ensuring exceptional design and project approach as MV+A expands in D.C. and other regions.

O

The 30-chapter international organization of volunteer humanitarian designers and architects once affiliated with defunct nonprofit Architecture for Humanity announces its new brand and identity as the **Open Architecture Collaborative**. Garrett Jacobs, the new Executive Director, and the OAC aims to address two fundamental issues in the built environment: lack of hands-on community experience for young professionals, and limited access to design services for marginalized communities. With the intention of ground-up governance informed by local issues, the OAC can empower local leaders to contribute resources and best practices to a global design network.

P

Perkins+Will is proud to announce the completion of the MedStar Health Bel Air Ambulatory Care Center in Harford County, Maryland. This three-story, 100,000 GSF facility is MedStar's largest free-standing ACC and will serve as a community center for health education and outreach in Bel Air, as well as providing outpatient service. Two other recent projects have earned LEED certification: the Washington office for MetLife with LEED-CI Platinum, and

the Whitman-Walker Health Clinic LEED-CI Gold. Perkins+Will is proud to have partnered on these two projects with clients who share a commitment to sustainability at this level.

S



Lindsay Allen, AIA



Peter Glaso, Assoc. AIA

Skidmore, Owings & Merrill congratulates Lindsay Allen, AIA, on her promotion to Associate. Lindsay brings ten years' experience as a technical architect with SOM to her new role as Project Manager. Her projects include the International Monetary Fund HQ1 Renewal and the New School University Center. SOM also welcomes Associate Peter Glasson, Assoc. AIA, and Katherine Russett, Assoc. AIA to the Washington, D.C. office.



Katherine Russett, Assoc. AIA

IMD

The expert staff at IMD can help communicate design ideas through innovative solutions customized to your project and audience.

90% OF PEOPLE CANNOT VISUALIZE 3D SPACE

MAKE YOUR IMAGES COUNT

CONTACT US TO LEARN MORE | ILLUSTRATEMYDESIGN.COM

3D Renderings | Cinematic Animation | 4D Construction Simulation | Virtual Reality

Over his 8 years at SOM New York, Peter has been recognized for design excellence and leadership on a range of transportation, mixed use urban development, and civic projects. Katherine joins the technical team from SOM New York with experience in education, commercial renovation and mixed use projects.

Streetsense is pleased to welcome several new members to its growing team. Duk Kim brings 20 years of global design experience to his new role as a Principal and Practice Group Leader for Interior Architecture. Brandon Diamond joins as Director of Architecture & Design, bringing 26 years of experience creating numerous high-profile large commercial projects in the U.S. and many international markets. **Marcel Péan, Assoc. AIA** has joined as an Architect, after serving as a staff architect at BBGM, with experience in the hospitality market sector. Libby Hampton has joined Streetsense as a Designer, focusing on restaurant and hospitality work. Prior to Streetsense, Libby was an Interior Designer with SFL+a Architects.

**HOLD YOUR NEXT MEETING
OR PRIVATE EVENT HERE!**

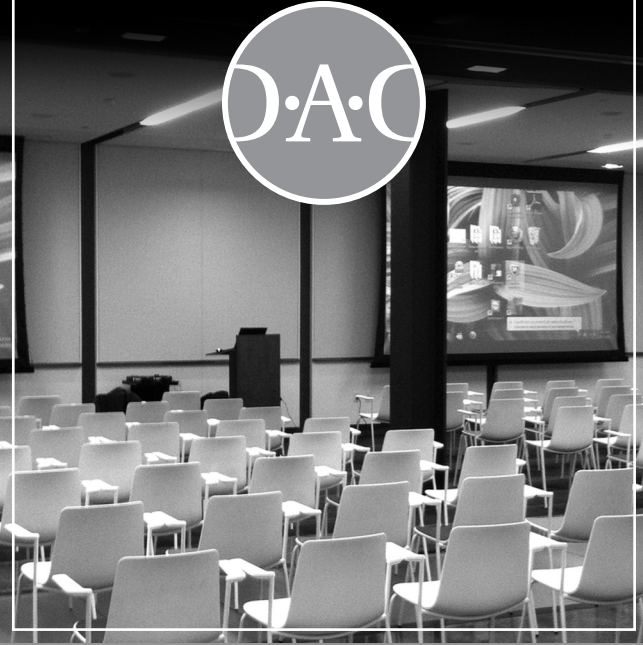

202-347-9403 • lheadrick@aiadc.com
www.aiadc.com



IRONSTAR
BUILDING COMPANY

ironstar.net

*Bringing commercial grade
construction management to
the custom residential market*

Build well. Create value. Construct relationships.



CAMPION HRUBY
LANDSCAPE ARCHITECTS

campionhruby.com
410.280.8850

Forrester
CONSTRUCTION

“Using Forrester’s quality management program on all projects ensures that the highest standards are met even on challenging projects.”

- **Mike Barnhart, PE**
Face of Forrester since 1997

Read more about the Faces of Forrester at www.forresterconstruction.com

KEEP BUILDING.

Hidden in Plain Sight

Custom Curved Diffusers

Underfloor & Displacement

Chilled Sails & Active Beams

Havtech is committed to providing custom solutions for every project. That’s why we offer Price® products, the preference for air distribution.

- Architectural Integration:** Designed to reflect your creative vision.
- Energy Efficient:** Multiple opportunities for significant energy savings.
- Indoor Environmental Quality:** Provides you with a quieter, cleaner air comfort experience.
- Flexibility:** Custom sizes, shapes and finishes facilitate design freedom.

Havtech. Innovative Solutions. Exceptional Service.

Call 301.206.9225 or visit havtech.com for more innovative air distribution solutions.

PRICE
HAVTECH.COM

Wagner Roofing
101 Years
Since 1914

MAHAN HALL, US NAVAL ACADEMY
NEW SLATE AND COPPER ROOFING

Wagner Roofing is proud of its 101 years of quality service on historic and residential properties.

- Commercial & Residential
- Copper, Slate & Tile
- Ornamental Metal
- Gutters & Downspouts
- Flat Roofing
- Historic Restorations

(301) 927-9030
WAGNERROOFING.COM

AHA
CONSULTING ENGINEERS

Mechanical
Electrical
Plumbing
Fire Protection
Energy
Commissioning
Tel/Data/Security/AV
Sustainability/LEED

Boston Atlanta Washington DC
www.aha-engineers.com

IS THERE A HOLE IN YOUR PLAN?

Before you get started on your next project, make the decision to incorporate natural gas into your design plan. In addition to offering a host of resources, our teams possess the technical skills to understand your design requirements and will give you the solutions you need—without compromising aesthetics or functionality. Make your next project the best it can be. Choose gas.

BuildSmartChooseGas.com

Washington Gas
A WGL Company

Barbara G. Laurie Scholarship Program Application Deadline

Date: Friday, May 6, 5:00 PM

AIA | DC and WAF sponsor a scholarship for DC high school students entering architecture undergraduate degree programs. Applicants must be residents of the District of Columbia and completing high school in a public, private, or charter school in the District. The scholarship is renewable each year (up to five years) if the student remains in an Architecture program.

Call for Entry Model Exhibition at the District Architecture Center

Date: Friday, May 6, 11:59 PM

Location: District Architecture Center, 421 7th Street, NW

More than loose freehand sketches, intricate technical drawings, or sleek computer renderings, the maquette, or scale model, serves as an excellent representation that bridges the gap between spatial idea and spatial construct. Scale models are communicative tools in three-dimension that give designers the power to experiment, solve problems, and help clients imagine a design. Despite advances in computer modelling software, which renders the scale model outdated for some designers, the traditional – physical – scale model remains a tested instrument in the design process. Submit your model for a chance to be featured at the District Architecture Center's exhibition this summer.

Washingtonian Awards Call for Entries

Date: Monday, May 9, 6:00 PM

Location: District Architecture Center, 421 7th Street, NW

To encourage excellence in local residential architecture, the Washingtonian magazine and AIA | DC announce the 35th annual Washingtonian Residential Design Awards Program. Distinctive residential projects, regardless of size or classification, will be recognized on the basis of excellence in total design, including aesthetics, programmatic response and sustainability. Public attention and acclaim will be focused on the winning submissions through coverage in the *Washingtonian* and in *ArchitectureDC*.

ARE: Take 5! Study Session

Date: Monday, May 9, 6:00 PM – 8:00 PM

Location: District Architecture Center, 421 7th Street, NW

Attend a review session led by seasoned professionals who specialize in these ARE 4.0 exams: Construction Documents & Services, Programming, Planning & Practice, and Site Planning & Design. Sessions are led by licensed registered architects or professional engineers (PE), supported by assistant instructors who have recently passed the division for which they are assigned. Participants are encouraged to address division-specific questions to the primary instructor or assistant instructor for that division. Have you registered for the ARE: Take 5! program yet? You must be registered to participate in the study sessions.

EDGE Green Building Software & Certification

Date: Monday, May 9, 6:30 PM – 7:30 PM

Location: District Architecture Center, 421 7th Street, NW

Discover how to design resource-efficient buildings in 125 emerging market countries with EDGE, a new software and green building certification system that is an innovation of IFC, a member of the World Bank Group. Entrepreneur Prashant Kapoor will demonstrate the software and present the business case for why architects should introduce their clients to this fast, easy, and affordable way to build and brand green. Organized by: AIA | DC High Performance Building Committee. *Credits: 1.0 HSW | LU. Fees: \$10 for students and Assoc. AIA members; \$15 for AIA & DAC members; \$35 for non-members. Registration required.*

The Thing in the Spring

Date: Thursday, May 12, 6:30 PM – 8:30 PM

Location: District Architecture Center, 421 7th Street, NW

Mix, mingle, network, view a live stream of the bee hive that has just been installed on the roof, and toast to 5 years of the District Architecture Center with others in real estate, design, development and architecture. Enjoy the full open bar as we enjoy the evening at the DAC! All for a good cause as we give out this year's Barbara G. Laurie Scholarships and support the GREAT WORK of the Washington Architectural Foundation. Insider tip: bring colleagues to discount your ticket!

Coffee and a Course: Building What Has Already Been Built - Revit for Existing Buildings

Date: Friday, May 13, 8:30 AM – 9:30 AM

Location: District Architecture Center, 421 7th Street, NW

Learn how to set up a project to take advantage of Revit's parametric and database capabilities to provide a whole building system that streamlines the documentation of existing building work. Attendees will leave the seminar with a checklist and a roadmap on how to best utilize Revit for your next existing building project. Presented by: Purvi Gandhi Irwin, AIA LEED AP BD+C. Sponsored by: CADD Microsystems. *Credits: 1.0 LU. Fees: Free for AIA & DAC members; \$25 for non-members. Registration required.*

Children's Walking Tour of Penn Quarter

Date: Saturday, May 14, 10:00 AM – 12:00 PM

Location: District Architecture Center, 421 7th Street, NW

Discover buildings! This walking tour for children will take a hands-on approach to learning about architecture in the vibrant Penn Quarter neighborhood during a walking tour led by architect Mary Kay Lanzillotta, FAIA. Participants will learn new terms like keystone, cornice, pilaster, pediment, portico, and many more architectural features that make up buildings. After the tour, the children can incorporate the architectural details that they learned into their own cardboard buildings. Parents are invited to join the tour and participate in the building process. *Fees: \$5 per child. Registration Required.*

Check out the online calendar at aiadc.com/calendar for a complete list of upcoming events.

Free design and engineering support for wood buildings



Nationwide support for the code-compliant design, engineering and construction of non-residential and multi-family wood buildings.

- Allowable heights and areas/construction types
- Structural detailing of wood-frame and hybrid material systems
- Fire resistance and acoustical-rated assemblies
- Efficient and code-compliant lateral system design
- Alternate means of code compliance
- Energy-efficient detailing
- Application of advanced building systems and technologies



woodworks.org/project-assistance • help@woodworks.org

MULTI-RESIDENTIAL/MIXED-USE • EDUCATION • OFFICE • COMMERCIAL • INDUSTRIAL • CIVIC • INSTITUTIONAL



A place where old world craftsmanship and cutting edge technology meet to create a new standard of high-end windows & doors for discerning clientele.

www.lepagemillwork.com



1.888. TW.PERRY www.twperry.com



TW Perry Architectural Window Consultants
....for a well informed decision

windowsmetrodc@twperry.com

BALTIMORE, MD — CHEVY CHASE, MD — GAITHERSBURG, MD — LEESBURG, VA — SPRINGFIELD, VA