

# NATIONAL GALLERY OF ART



EAST BUILDING RENOVATION & EXPANSION

# BUILDING HISTORY

The National Gallery of Art is one of the world's leading art museums with a significant collection of American and European masterworks. Maintaining high standards of excellence and achievement, as well as service to the nation, continues to be the National Gallery's highest priority. The mission of the Gallery is to serve the country by preserving, collecting, exhibiting, and fostering understanding of works of art for the American Public.

The East Building, opened to the public in 1978, is itself a work of "art in architecture" on par with the artwork it exhibits. Designed by the world-renowned architect I.M. Pei, the East Building houses and protects modern collections of paintings, works on paper, sculpture, textiles, and decorative arts. The building preserves the collection and makes it readily available to the American public and visitors from around the world in a safe and secure environment.<sup>1</sup>

The East Building Renovation and Expansion Project was multifaceted and affected nearly all spaces in the public galleries and included life safety and fire protection improvements; mechanical, electrical, plumbing, and elevator updates; building envelope improvements; new gallery space, sculpture terrace, egress stairs, and art movement/public elevator. The goal was to create new spaces, provide additional code-compliant exit-ways that simultaneously enhance the visitor experience, but not alter the existing character of the building.

<sup>1</sup> Excerpt from [www.nga.gov](http://www.nga.gov)







## PROJECT BACKGROUND

In 1997, the National Gallery of Art initiated a Master Facilities Plan (MFP) and then began to implement a program of federally funded capital projects. The renovation projects focused on reducing risks and extending the useful lives of their buildings, and the critical building systems that support and protect the collections, visitors, and staff. In preparation for renovation in the East Building, an update to the MFP was completed in 2012. This updated the blueprint for determining how best to renew the building's aging infrastructure with minimal disruption to Gallery operations and public programs. The MFP for the East Building is being implemented in phases, the first of which coincided with a small gallery expansion project.

As part of the MFP, the Gallery completed a Fire Risk Assessment for the East Building, which identified important life safety and fire protection improvements, including the addition of new fire egress stairs. As it has done in the past, the Gallery's management contacted I.M. Pei to seek his advice and input for these improvements. He, in turn, recommended Perry Y. Chin, a longtime associate, to be his liaison with the Gallery.

Mr. Chin and the Gallery saw an opportunity to create new egress stairs in existing hexagonal shafts and at the same time expand gallery space in the two tower "attic" spaces above the existing laylights. These new tower galleries could also be accessed via a new public roof terrace at the roof along Pennsylvania Avenue. This concept of two new "Tower Galleries" in Towers 1 and 2 connected by a new Sculpture Terrace across the "north bridge" was presented to the Board of Trustees in 2009. A key aspect of this proposal was minimal changes to the building's architectural integrity, exterior and interior. The Gallery's leadership embraced the design concept and the privately funded gallery expansion (EBX) was executed in tandem with the federally-funded improvements – a true public/private partnership.

## DESIGN APPROACH

IM Pei's design of the East Building transformed the odd trapezoidal shape of the site into an artful geometric expression of L'Enfant's 1791 plan for Washington, DC. The basic form is composed of two triangular prisms, where the public gallery portion is an isosceles triangle in plan, centered on the east-west axis of John Russell Pope's West Building.

Three "pod" towers, with bridges and linkages between them, define the west and north boundary of the isosceles triangle. Each tower now contains a "house gallery" surrounding the atrium. Within the parallelogram shaped pods, galleries are subdivided into regularly shaped hexagons with the less regular surrounding space for services such as stairs, elevators, and mechanical/electrical risers.

The building's plan has an underlying grid of isosceles triangles (30 x 45 x 45 inches). Expressed literally in the joints of the stone flooring, the grid is the framework for all building forms and details.

The Renovation and Expansion Project created new architectural elements inserted into the existing structure. To the greatest extent possible, the design respects and adheres to the grid, as well as to the formal and detail master plan set by Mr. Pei's design. Any deviations were made in a thoughtful and logical way, designed to minimize the impact of the alterations on the existing architectural fabric.

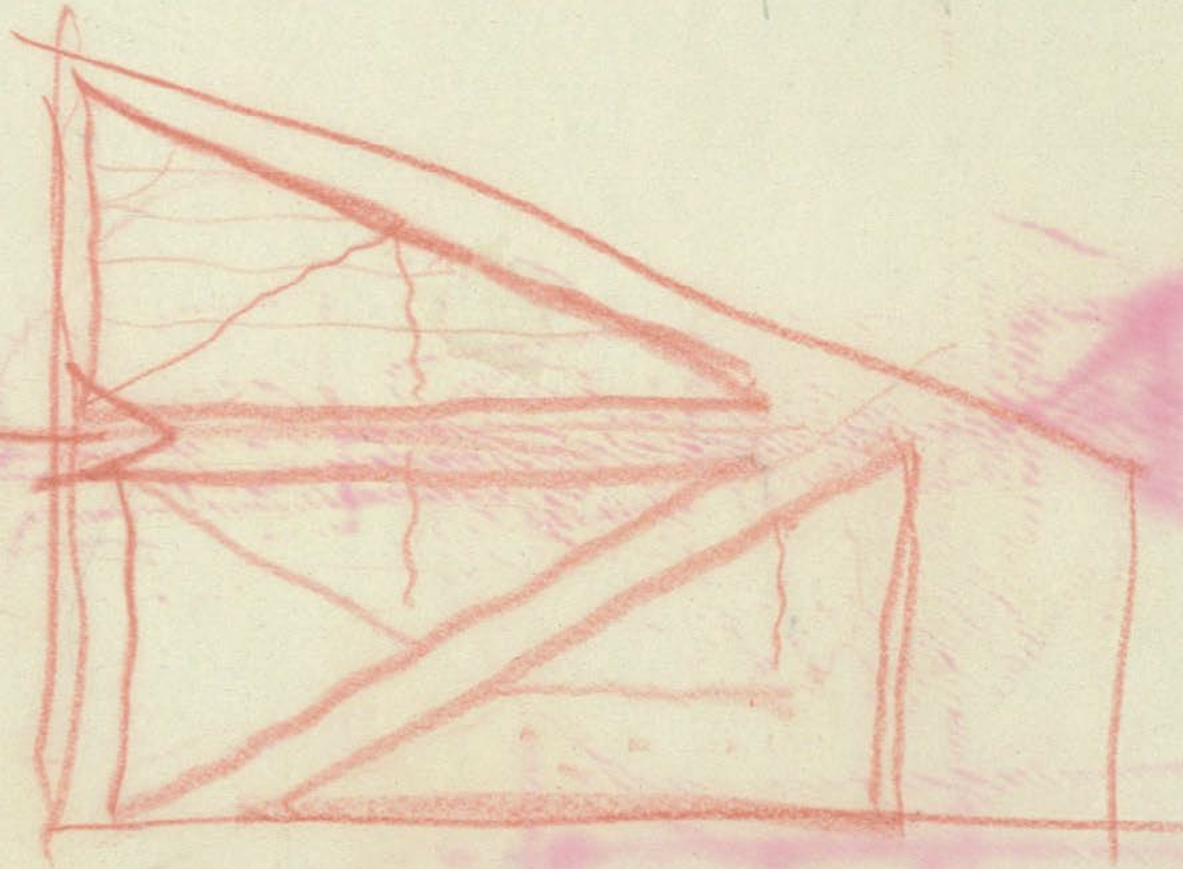

IMP sketch first part: N. 9  
Fall 1968





## PROJECT DESCRIPTION

The MFP Project scope is multifaceted and affects nearly all public spaces in the East Building:

- **Life safety improvements:** two new egress stairs in Towers 1 and 2 that now serve all gallery levels.
- **Fire protection improvements:** partial installation of a smoke evacuation system for the main atrium; establishing smoke compartments segregating the galleries from the Atrium; and installing sprinkler systems in the Concourse galleries.
- **Building envelope improvements:** replacement of roofing and skylights in Towers 1 and 2 and on the North Bridge
- **Mechanical, plumbing, electrical, telecommunications, and elevator updates** are also included along with other accessibility improvements.

The EBX Project scope:

- **Two new galleries** on Level 6 in what was originally unoccupied space above the skylights in Towers 1 and 2.
- **New Sculpture Terrace** created on the North Bridge roof that connects the new Level 6 Galleries.
- **Third egress stair** from the Sculpture Terrace to the Level 4 Gallery.
- **New art movement/public elevator** added to Tower 2 to service the Concourse and Levels 1, 2, 4, and 6.



# STONE SELECTION

The existing stone floors and walls of the public side of the building are almost exclusively Tennessee Pink marble. As the goal was to provide the same approach to materials, textures, and finishes found in the existing spaces for all new work, the new elevator lobbies and egress stairs were painstakingly matched to the existing stone. However, for the new Sculpture Terrace pavers, benches, and planters, Lac du Bonnet granite was chosen. The granite was selected for its durability and slip-resistance as a horizontal surface; as well as its compatible color range with the Tennessee Pink marble.

During the selection process, both quarries were visited where slabs and blocks were reviewed by the design team with respect to color, "movement," and veining. Due to the precise geometry of the building, fabrication tolerances and joint intersections were discussed in great detail. The over-arching goal for each space was to fit seamlessly into the existing fabric of the building, and the stone selection was no exception.

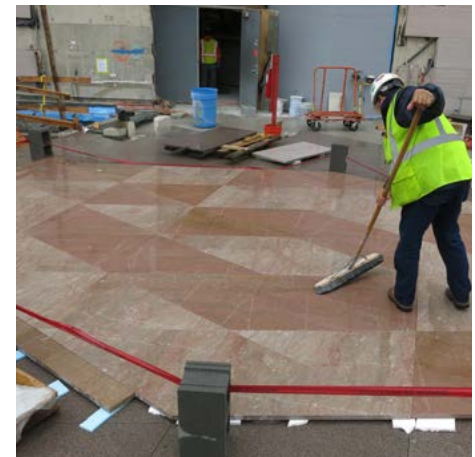
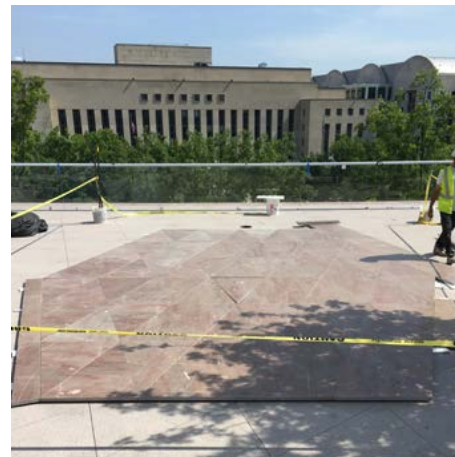
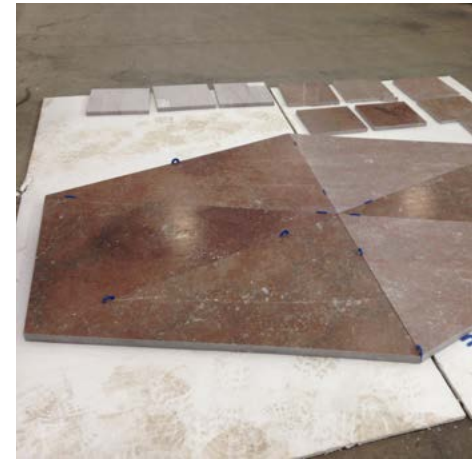





## SCULPTURE TERRACE & STAIR

The Sculpture Terrace includes hardscape and landscape elements for display of sculpture and visitor contemplation overlooking Pennsylvania Avenue. The third egress stair was added at the east end of the terrace for occupancy load, but it also provides an opportunity for a gracious public connection to the Level 4 gallery space.

The terrace design includes raised tree planters, similar in form to those found in the atrium space below, and a linear planter with a line of trees along the Main Atrium skylight. The stone paving is on the triangular grid established by I.M. Pei and continues down the stair. The landscape elements and openings from the terrace to the Tower Galleries are outside the view shed from Pennsylvania Avenue.



△ Existing ballast roof prior to the renovation/expansion project

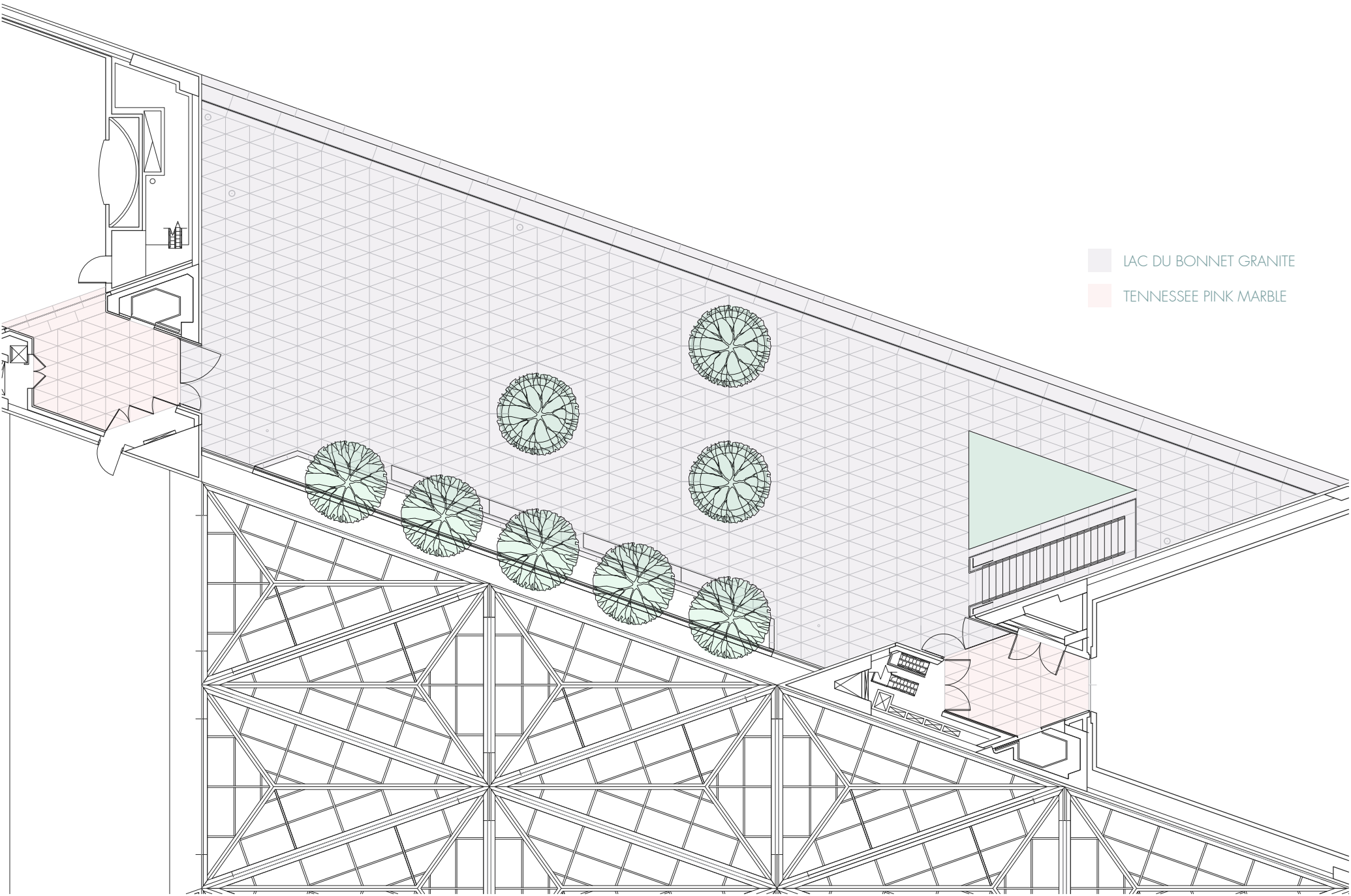

LAC DU BONNET GRANITE

TENNESSEE PINK MARBLE

SCULPTURE TERRACE PLAN



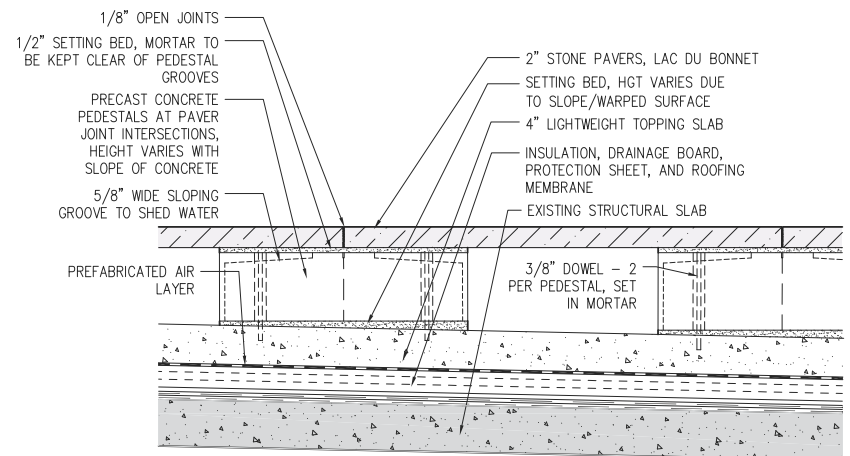
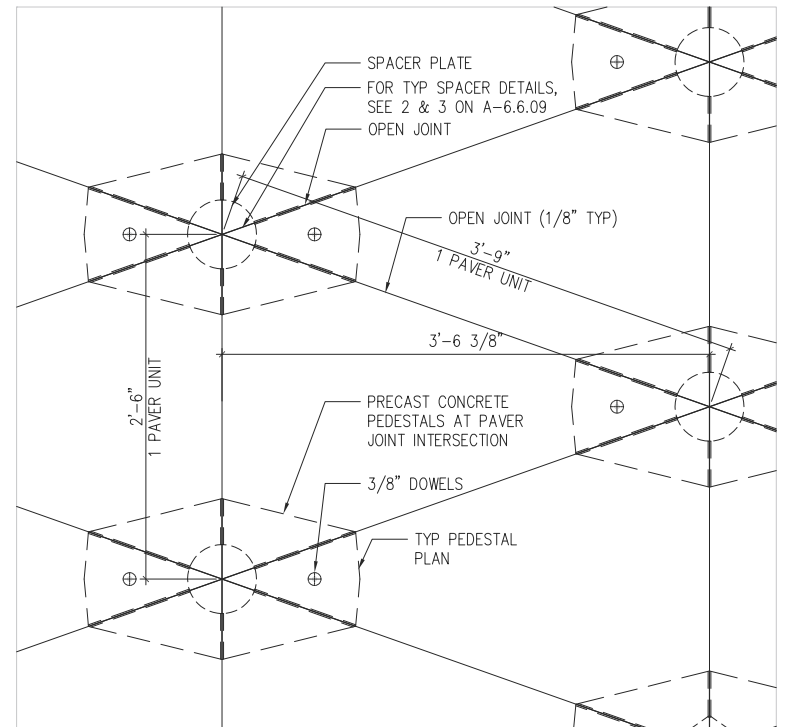



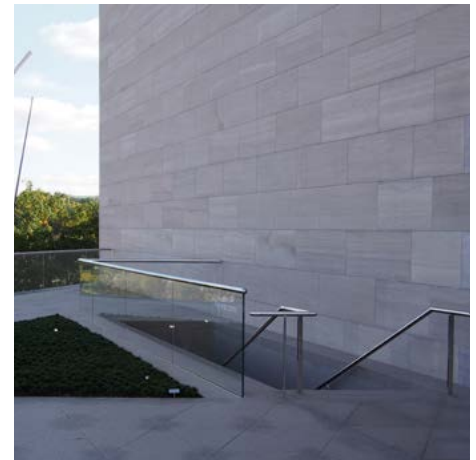
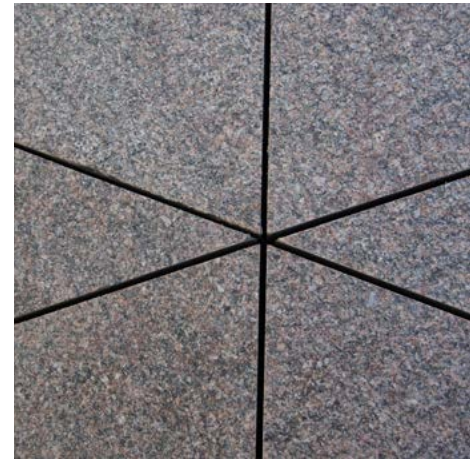
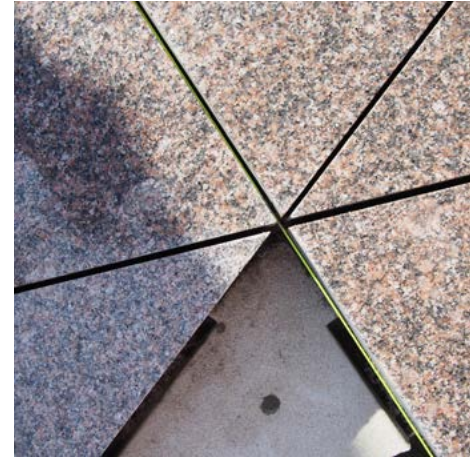

STONE DETAILS  
& INSTALLATION



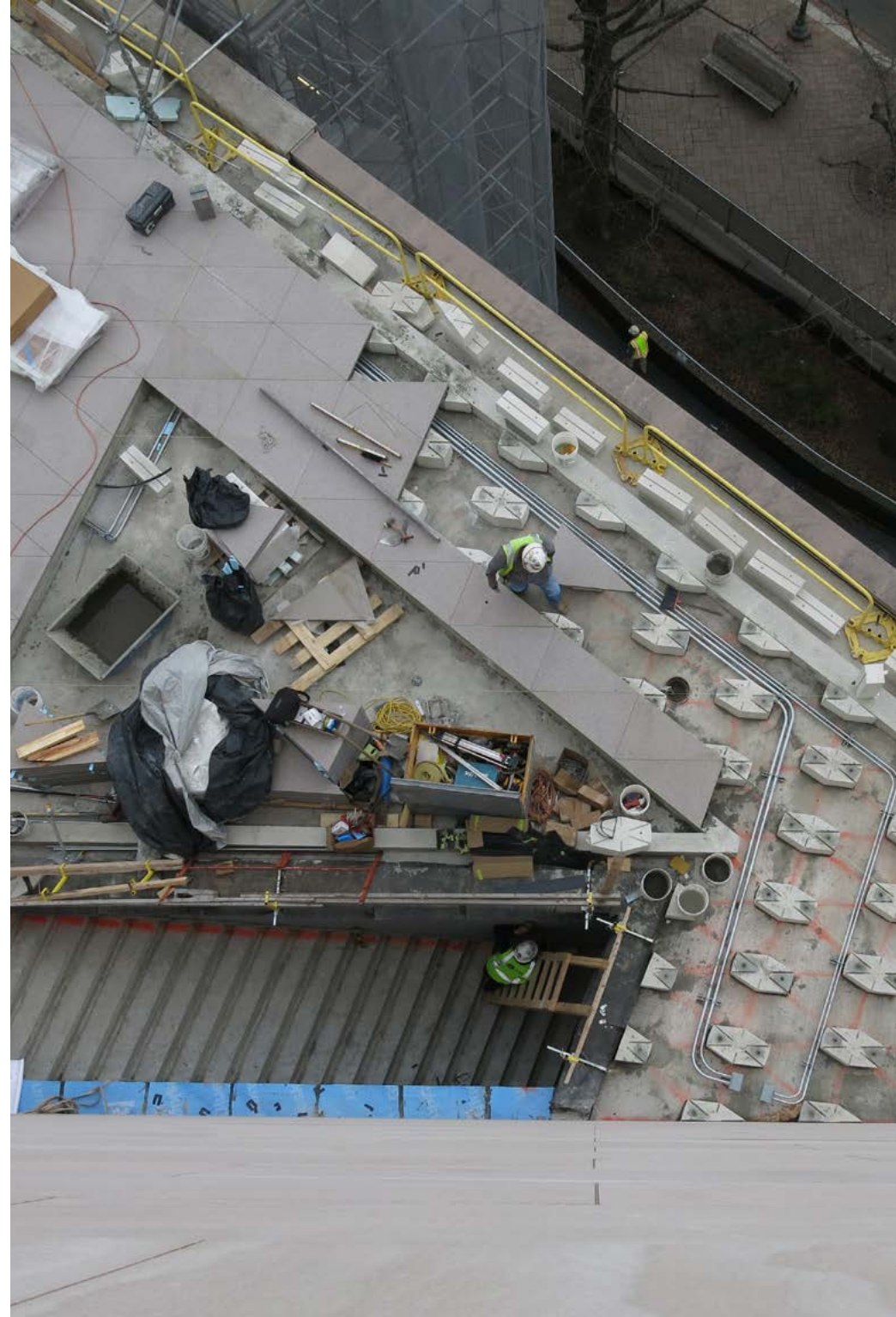









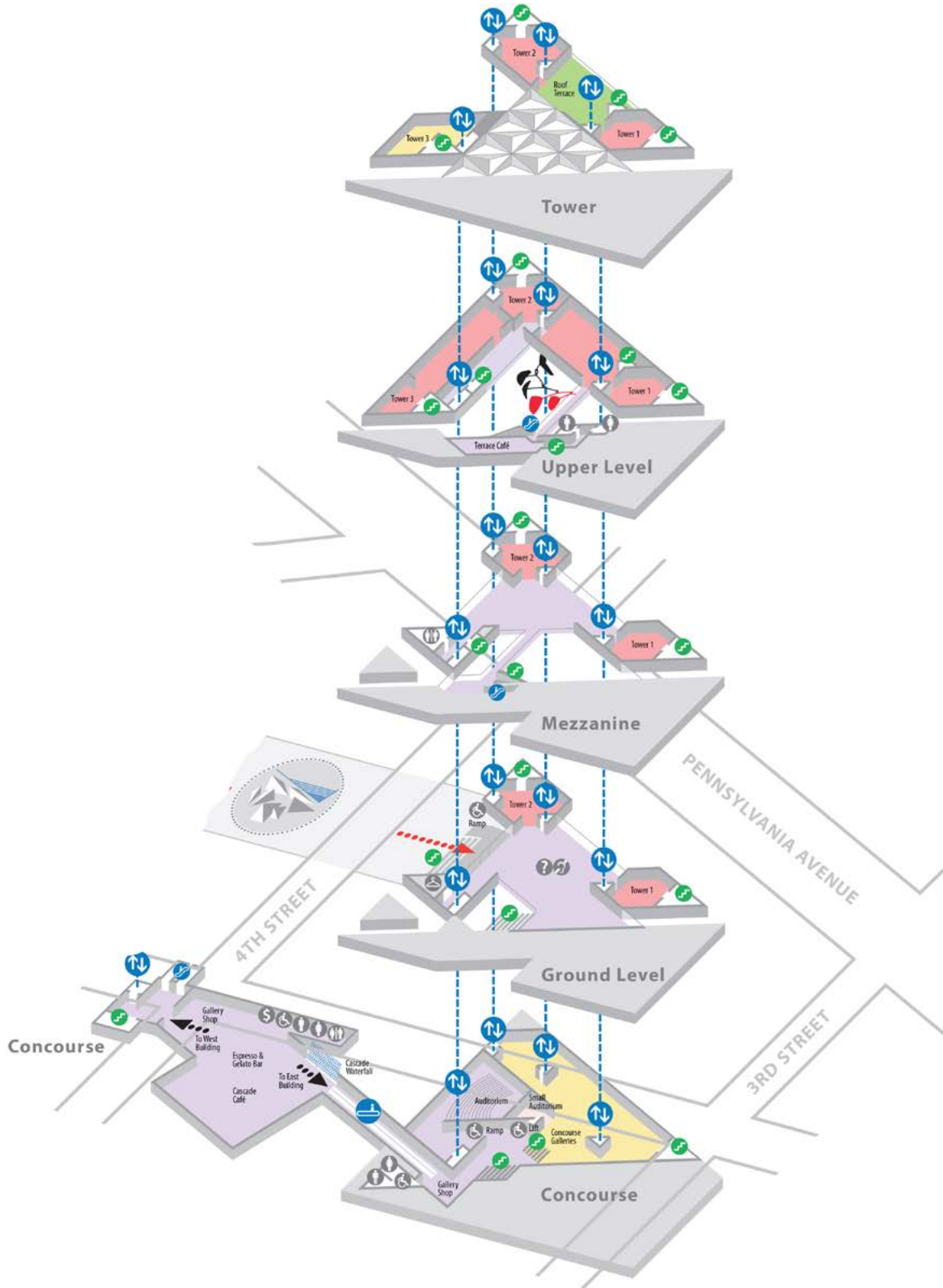

## INTERIOR PUBLIC SPACE

In space that was previously unoccupied, the new skylit **Tower Galleries** present three of the modern masters most closely associated with the Gallery: Mark Rothko, Barnett Newman, and Alexander Calder. New wood floors, skylights, and laylights to match the existing were also installed.

As part of the permanent collection, the **Upper Level** and **Mezzanine Galleries** include a chronological presentation of modern art. As part of the renovation project, the gallery configuration was modified and fumed quarter-sawn oak wood floors were installed, same as the West Building. The renovation project presented a significant opportunity for the Gallery to return the permanent collections to the Upper Levels as originally intended.

Previously devoted to long-term exhibitions, the **Ground Level Galleries** have been reconfigured to focus on two pillars of the Gallery's permanent collection of modern art.

The **Concourse Galleries** include the changing special exhibitions, which were relocated from the Upper Levels and new terrazzo flooring was installed.



## NEW TOWER GALLERIES & EGRESS STAIRS

Through the Expansion and Renovation project, an impressive 12,250+ square feet of gallery space were added without altering the form of the building. The new space enables the Gallery to present more art and accommodate more visitors than ever before.

The new tower level, re-installed galleries, and new egress stairs “unlock” the building’s potential and improve the flow for visitors as they can move throughout the building more freely than in the past. All floors are now connected to enhance exploration of the works of art installed on all levels of the building.

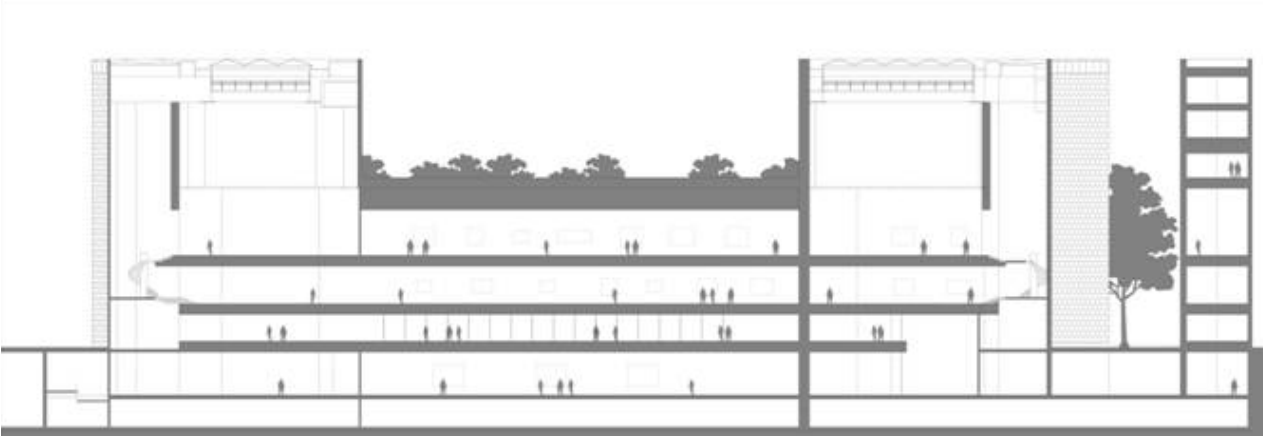

**BUILDING SECTION:** before construction, the upper levels did not utilize the space below the skylights as occupiable gallery space, the roof was not occupiable, and the egress stairs did not provide access to each level.

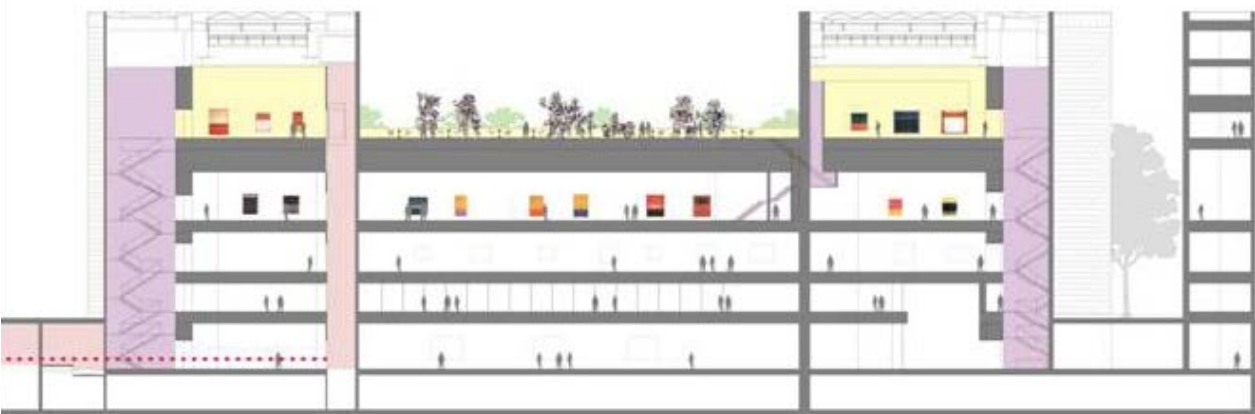

**BUILDING SECTION:** after construction, the upper levels provide 12,000+ SF of new gallery space within the existing building footprint, the enlivened sculpture terrace connects the towers, and every level of the gallery is connected by the new egress stairs

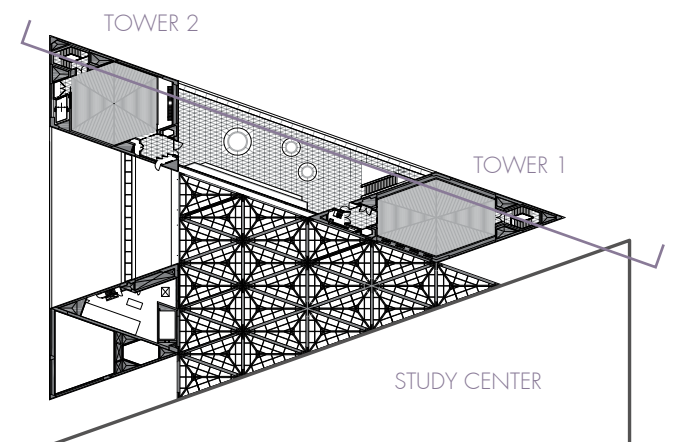





## LEVEL 6 NEW TOWER GALLERIES

By relocating existing mechanical and electrical equipment and service stairs above the Upper Level galleries, a new concrete and steel floor was constructed just above the existing laylight ceiling level to establish new gallery spaces at the Tower Level.

The northeast Tower 1 gallery presents abstract expressionist works, including a changing selection of paintings by Mark Rothko and Barnett Newman.

The northwest Tower 2 gallery showcases a lively installation of works by Alexander Calder – constituting the largest long-term gallery space in the world dedicated to the modern master.

















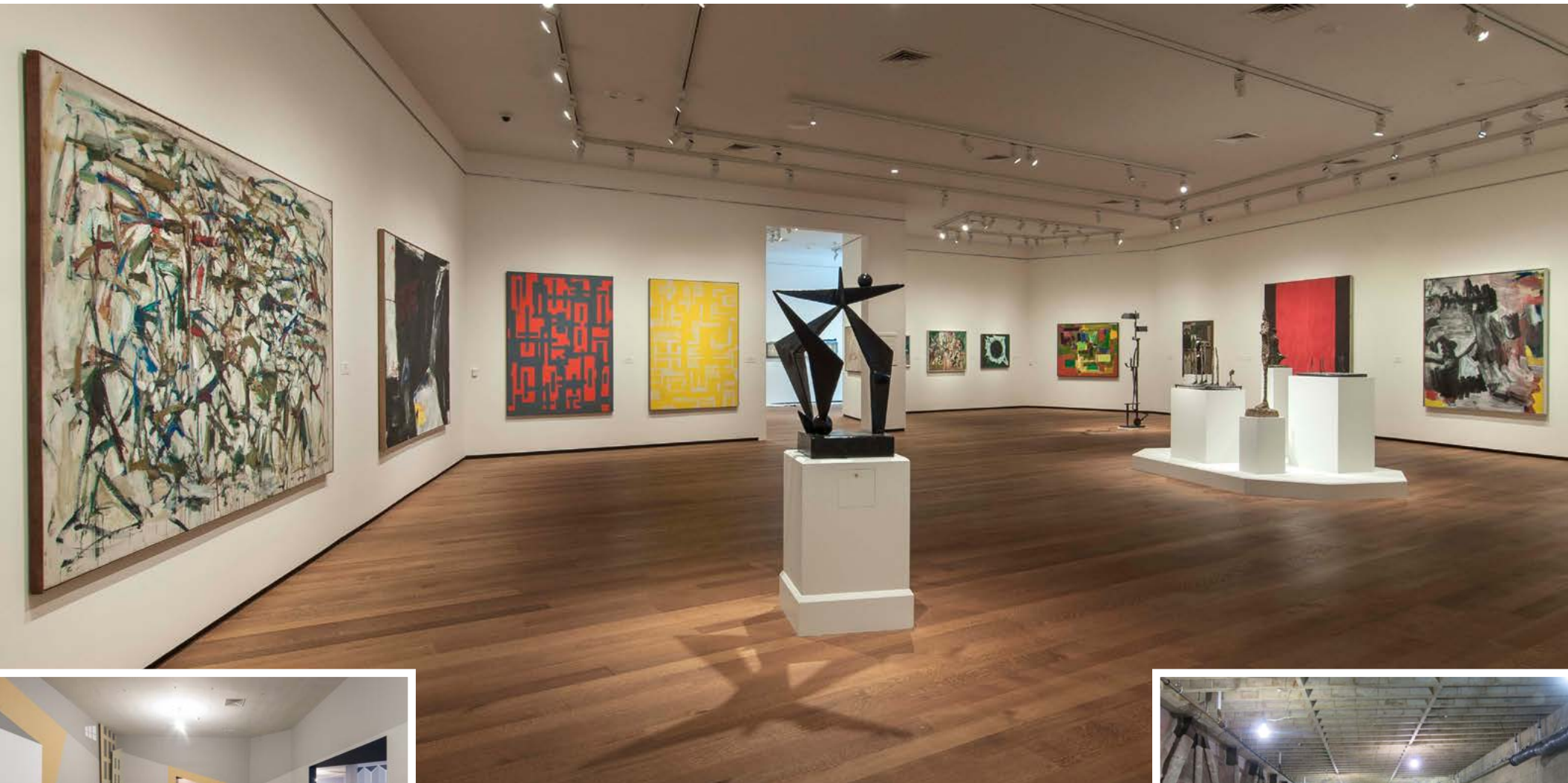

## NORTH BRIDGE UPPER LEVEL GALLERY

▲ before construction

All Photos Copyright © 2017 Board of Trustees, National Gallery of Art, Washington

after demolition ▲





## MEZZANINE GALLERY

▲ before construction

All Photos Copyright © 2017 Board of Trustees, National Gallery of Art, Washington

after demolition ▲

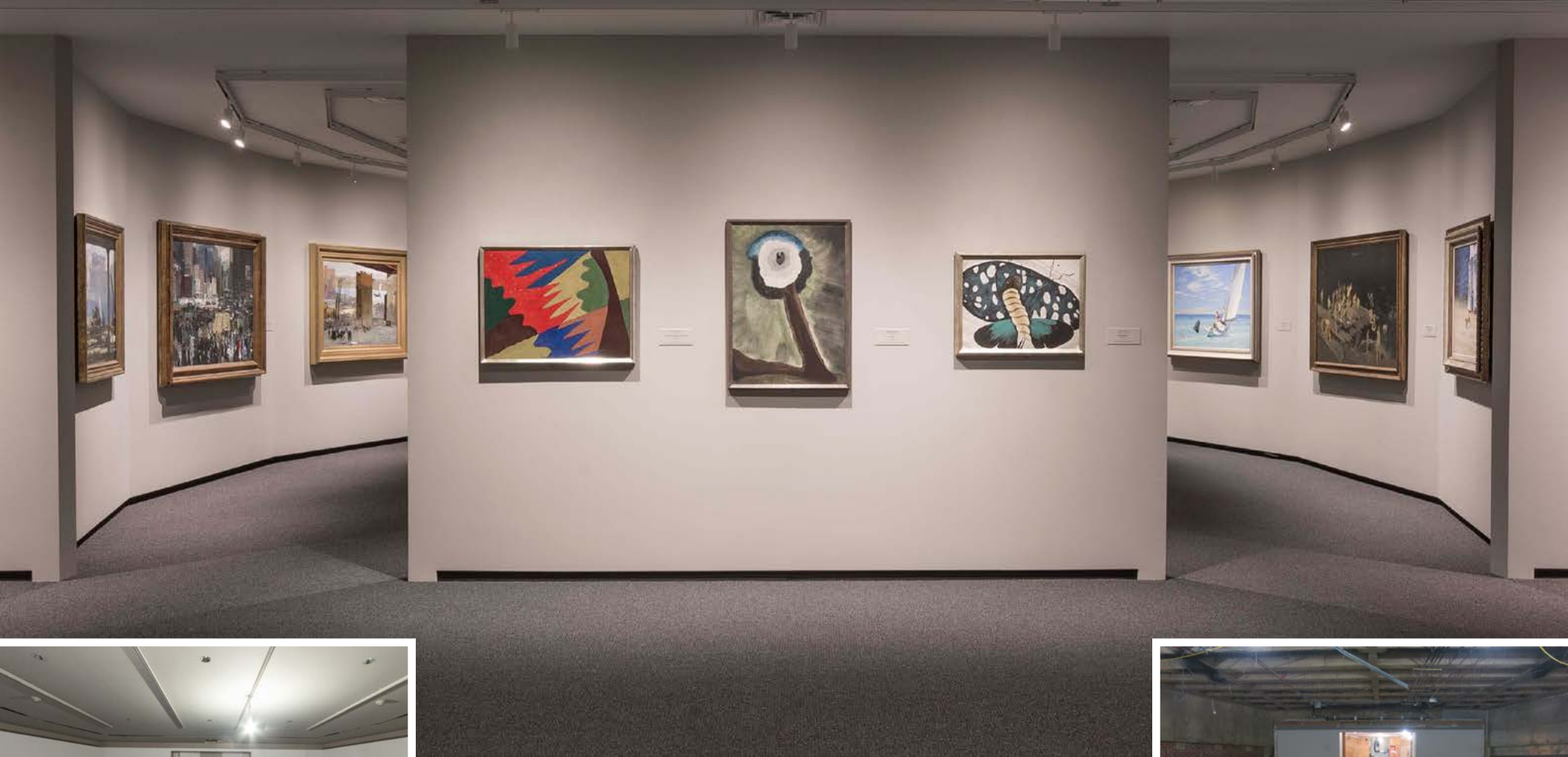

## GROUND LEVEL GALLERY



▲ before construction



after demolition ▲



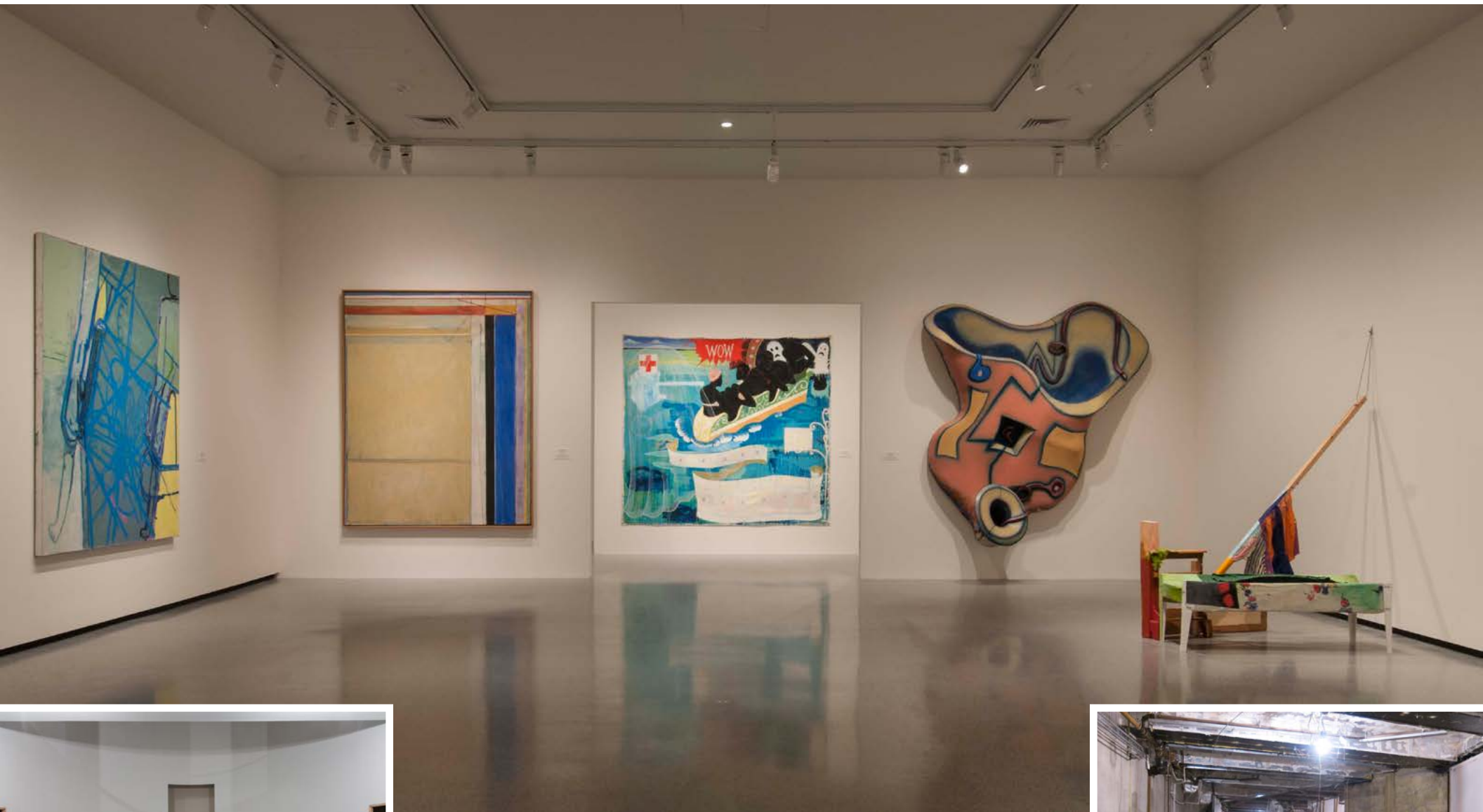

## CONCOURSE GALLERY

▲ before construction

All Photos Copyright © 2017 Board of Trustees, National Gallery of Art, Washington

after demolition ▲



STAIR 1

## TOWER STAIRS

The original spiral stairs were elegant and beautiful but did not connect to every floor level of the building. The new stairs provide access and egress to every floor level and are sympathetic with Pei's original design. The design of the stairs conforms to the triangular grid and makes full use of the existing hexagonal stair shafts. As with many of the spaces in the East Building, the module of the grid create the shape of the stair, creating an interesting rhombus shaped void at the center of the hexagon.

The design engages the outer wall as the stair treads cantilever off stringers embedded in the wall. The new stair subtly acknowledges the old spiral stair by inverting its relationship of the void within the shaft space. While the original spiral creates an object in the hexagonal volume, the new design creates a rhombus shaped open space in the center and moves the structure to the perimeter.



△ Existing spiral stairs were removed as they did not meet the necessary egress requirements

◁ Photos Copyright © 2017 Board of Trustees, National Gallery of Art, Washington



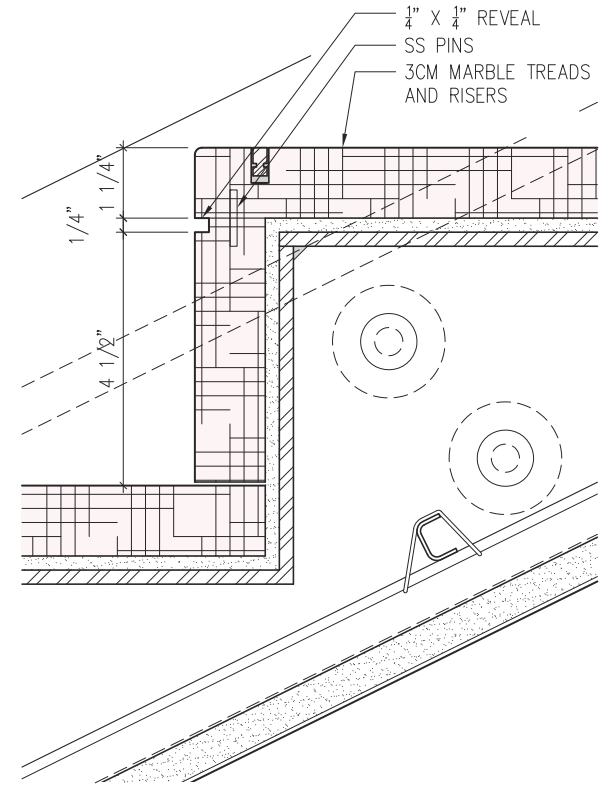
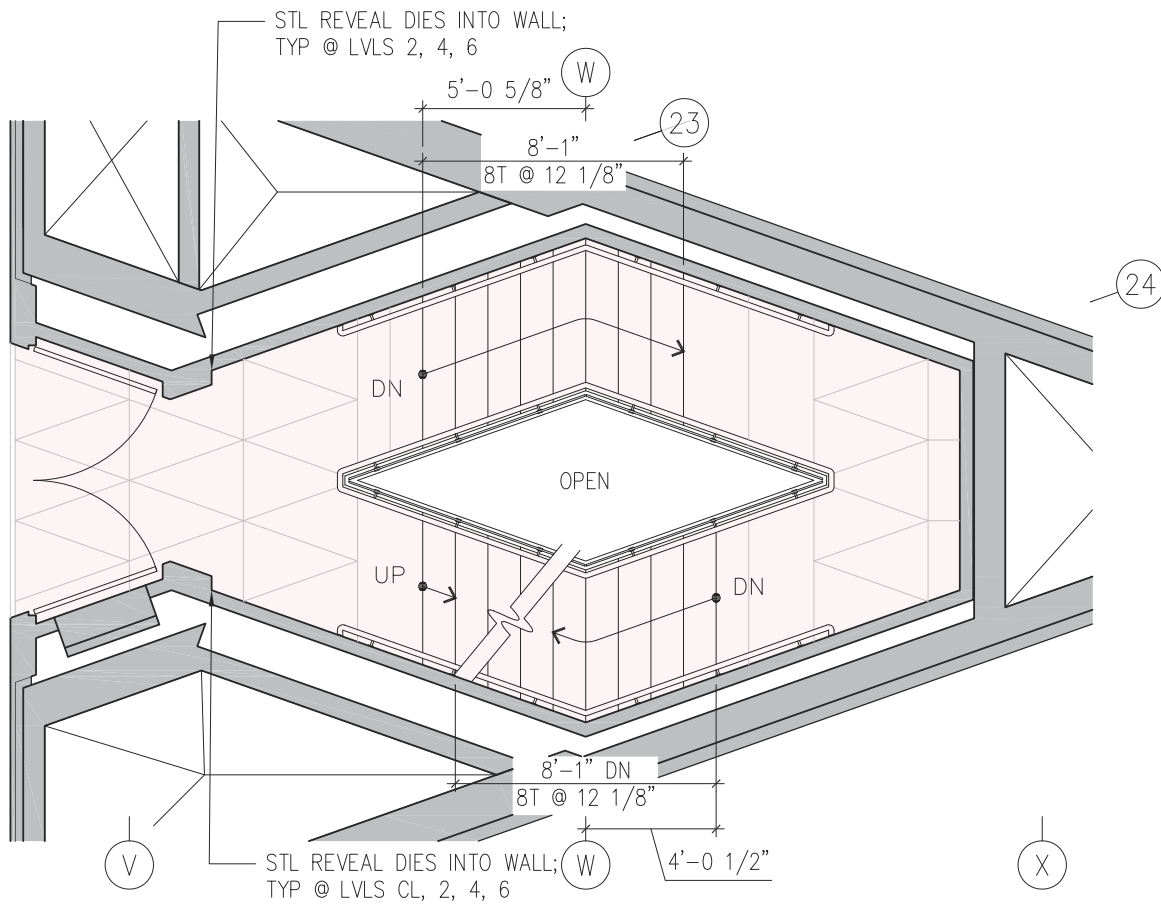

△ Typical Stair Plan

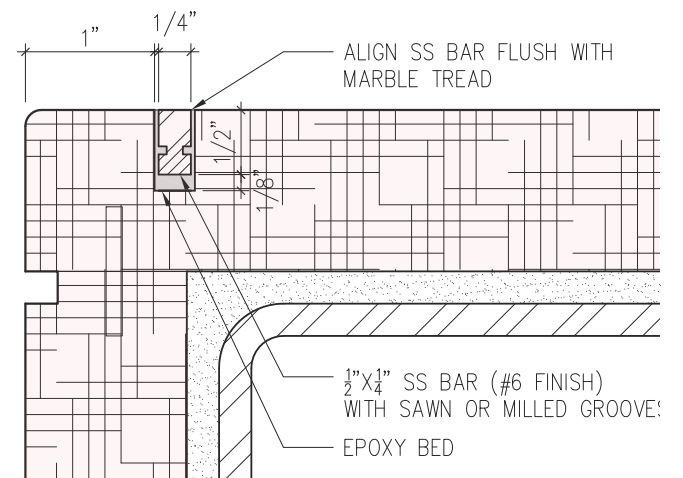
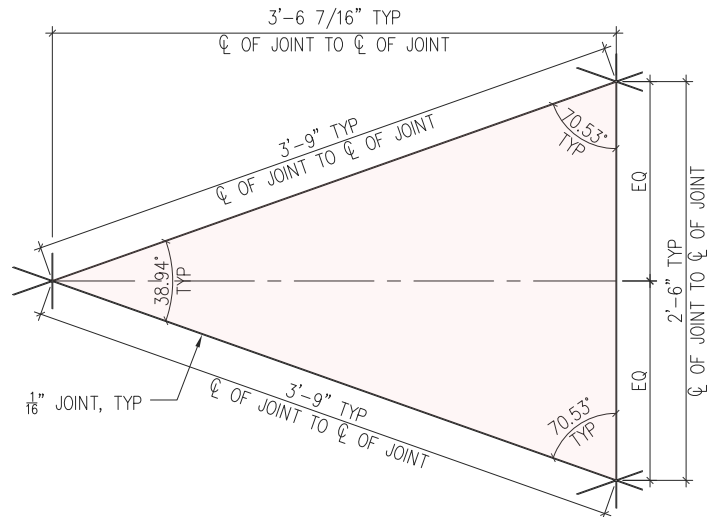

△ Typical Marble Tread & Riser Details

# TYPICAL STAIR DETAILS



*Dry-lay of Tennessee Pink Marble stair treads*



*Mock-up and review of stair*



*Final installation of stair*









STAIR 1



# NATIONAL GALLERY OF ART



EAST BUILDING RENOVATION & EXPANSION